

Scissor Lift Product Brochure

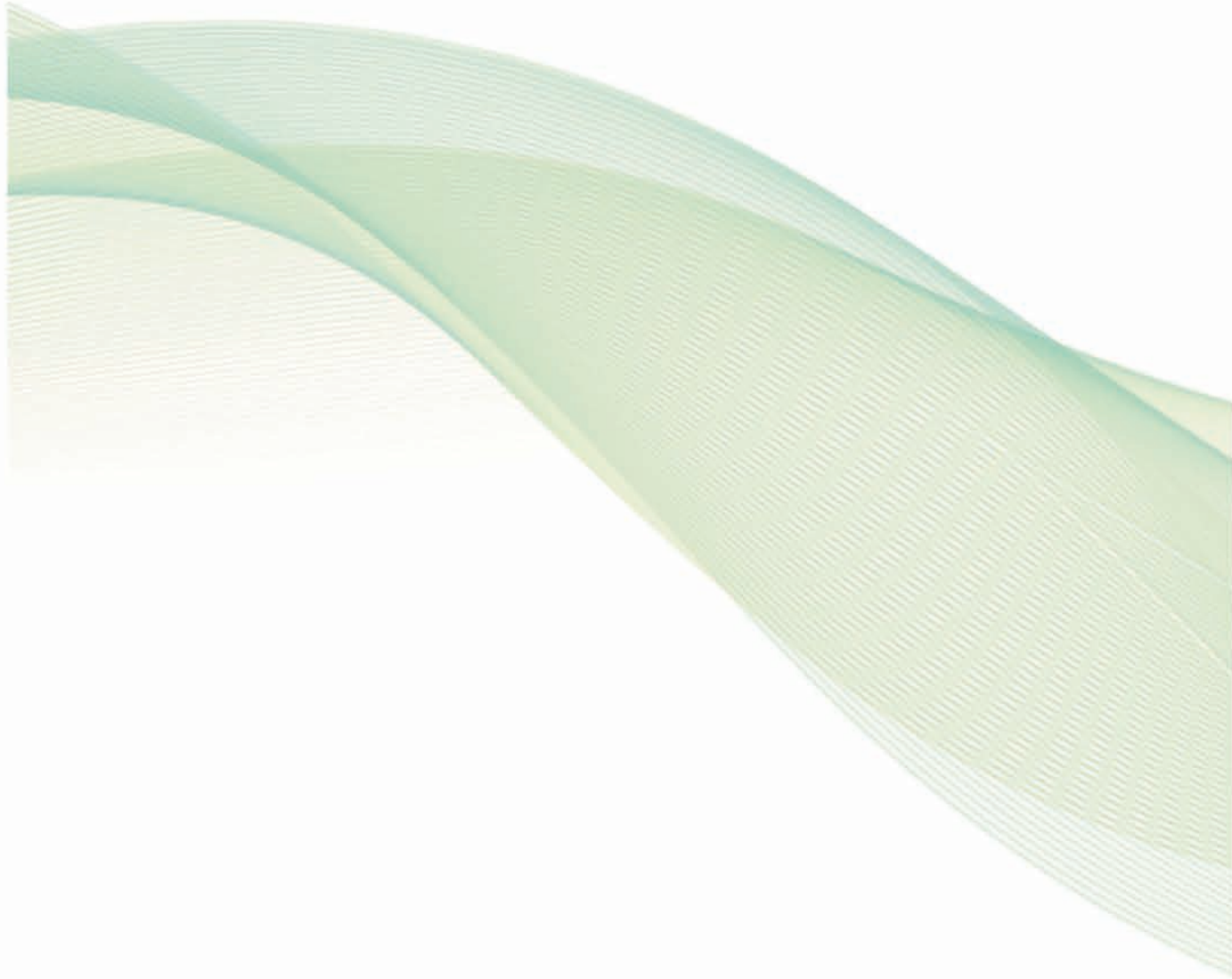

GT CONUTWAY
TEZA

■ Contents

01

Electric Scissor Lift

Platform Height: 4.2m~13.8m

Page 04



02

Tracked Scissor Lift

Platform Height: 7.8m~11.8m

Page 10



03

Bi-leveling Tracked Scissor Lift

Platform Height: 5.9m~12m

Page 12



Scissor Lift Series

scissor lift series offers platform height from 4.2 to 13.8 meters, including 3 categories: electric scissor lifts, tracked scissor lifts, and bi-leveling tracked scissor lifts. The maximum working height of the series covers 6.2-15.8m, and the maximum load is 320kg.

Electric Scissor Lift

compact electric scissor lifts have a lower platform height than a boom lift and can reach as high as 4.2-13.8 meters. Powered by batteries, electric scissor lifts are more environmentally friendly. They are ideally suited for indoor operation due to a lack of exhaust emissions or loud noises when operating.

Tracked Scissor Lift

Tracked scissor lifts have been designed to operate effectively on challenging terrain and slopes. These high-performance scissor lifts are highly versatile and are ideal for worksites where the space is limited and on uneven ground, where the tracks come into their own. tracked scissor lift is a compact scissor lift capable of operating up to 11.8m in height, and 320kg in load.

Bi-leveling Tracked Scissor Lift

A bi-leveling tracked scissor lift is equipped with bi-leveling technology making it ideal for challenging terrain slopes. Its compact size allows it to operate in small spaces, and a max working height of 14m means it is versatile enough for many different applications.

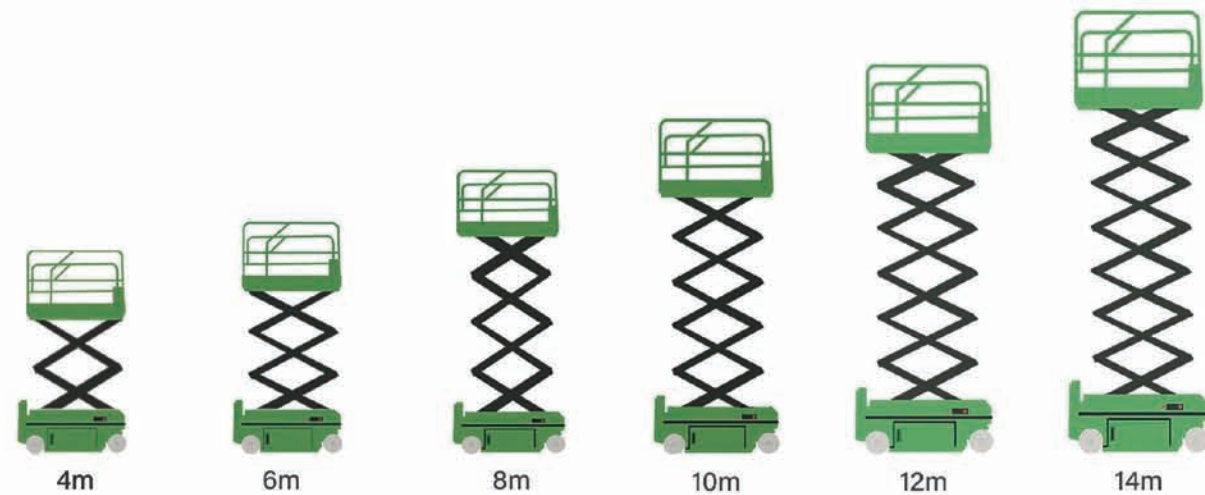

Z04N	Z06N	Z08N			
	Z06W	Z08W	Z10W	Z12W	Z14W

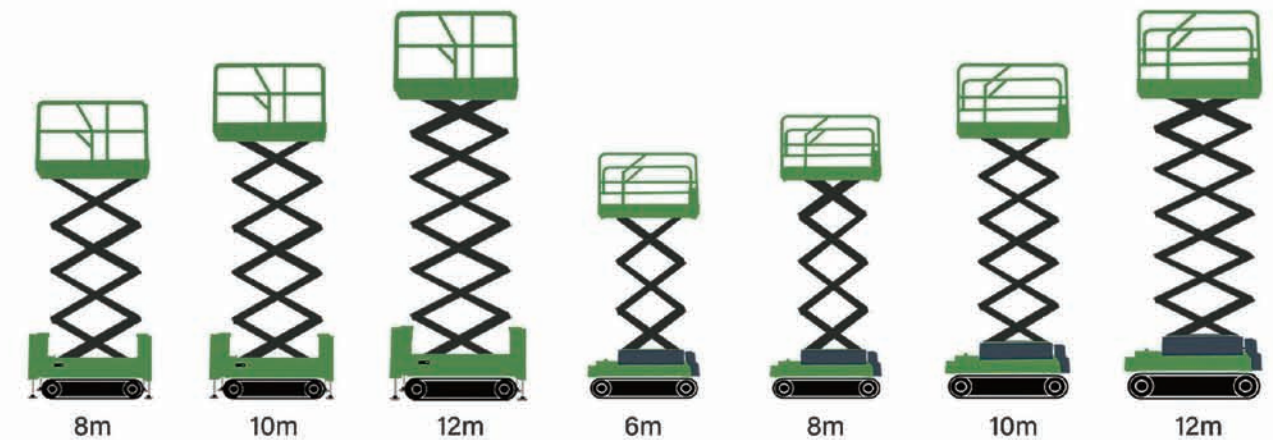

Z08T	Z10T	Z12T				
			Z06TSL	Z08TSL	Z10TSL	Z12TSL

Electric Scissor Lift

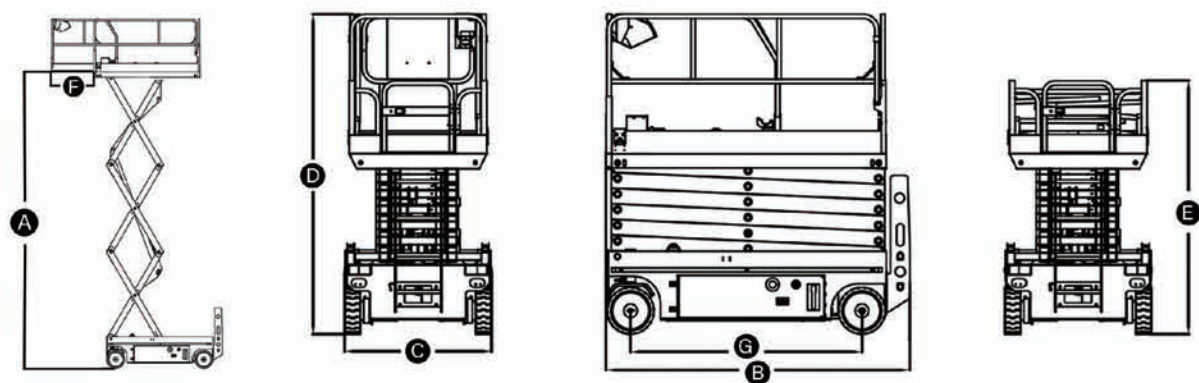

Model	Z04N	Z06N	Z06W
Specification			
Max. Working Height	6.2m	7.8m	7.8m
A Max. Platform Height	4.2m	5.8m	5.8m
Platform Length	1.29m	1.68m	2.3m
Platform Width	0.7m	0.74m	1.15m
B Overall Length	1.46m	1.83m	2.45m
C Overall Width	0.76m	0.76m	1.18m
D Overall Height-Guardrails Up	2.05m	2.18m	2.24m
E Overall Height-Guardrails Down	1.67m	1.8m	1.64m
F Extension Deck	0.6m	0.9m	0.9m
G Wheelbase	1.11m	1.36m	1.92m
Ground Clearance (Stowed/Raised)	0.083m/0.016m	0.083m/0.016m	0.1m/0.02m
Productivity			
Max. Platform Occupants	2	2	2
Platform Capacity	230kg	230kg	320kg
Platform Capacity-Extension Deck	90kg	113kg	113kg
Drive Height	Full Height	Full Height	Full Height
Gradeability-Stowed	25%	25%	25%
Turning Radius-Inside/Outside	0/1.39m	0/2.2m	0/2.8m
Raise/Lower Speed	3-5m/min	3-5m/min	3-5m/min
Drive Mode	2×2	2×2	2×2
Tire Type	Solid non-marking tire	Solid non-marking tire	Solid non-marking tire
Tire Size	φ305×100mm	φ305×100mm	φ380×127mm
Power			
Battery	2*12V/80Ah	4*6V/200Ah	4*6V/200Ah
Charger	24V/30A	24V/30A	24V/30A
Hydraulic System			
Hydraulic Oil Capacity	5L	10L	20L
Weight			
Machine Weight	880kg	1500kg	2050kg

Electric Scissor Lift

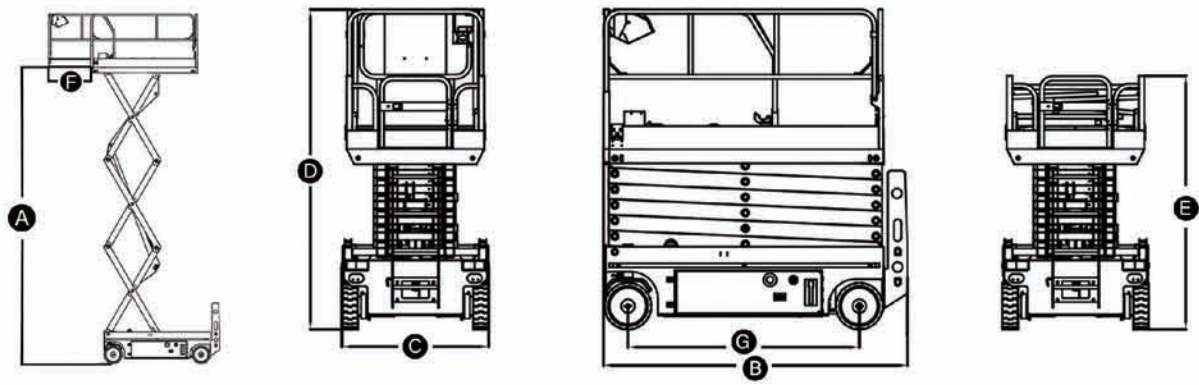

Model	Z08N	Z08W
Specification		
Max. Working Height	9.8m	9.8m
A Max. Platform Height	7.8m	7.8m
Platform Length	2.3m	2.3m
Platform Width	0.81m	1.15m
B Overall Length	2.45m	2.45m
C Overall Width	0.85m	1.18m
D Overall Height-Guardrails Up	2.36m	2.36m
E Overall Height-Guardrails Down	1.76m	1.76m
F Extension Deck	0.9m	0.9m
G Wheelbase	1.92m	1.92m
Ground Clearance (Stowed/Raised)	0.1m/0.02m	0.1m/0.02m
Productivity		
Max. Platform Occupants	2	2
Platform Capacity	230kg	320kg
Platform Capacity-Extension Deck	113kg	113kg
Drive Height	Full Height	Full Height
Gradeability-Stowed	25%	25%
Turning Radius-Inside/Outside	0/2.8m	0/2.8m
Raise/Lower Speed	3-5m/min	3-5m/min
Drive Mode	2×2	2×2
Tire Type	Solid non-marking tire	Solid non-marking tire
Tire Size	φ380×127mm	φ380×127mm
Power		
Battery	4*6V/200Ah	4*6V/200Ah
Charger	24V/30A	24V/30A
Hydraulic System		
Hydraulic Oil Capacity	20L	20L
Weight		
Machine Weight	2100kg	2150kg

Electric Scissor Lift

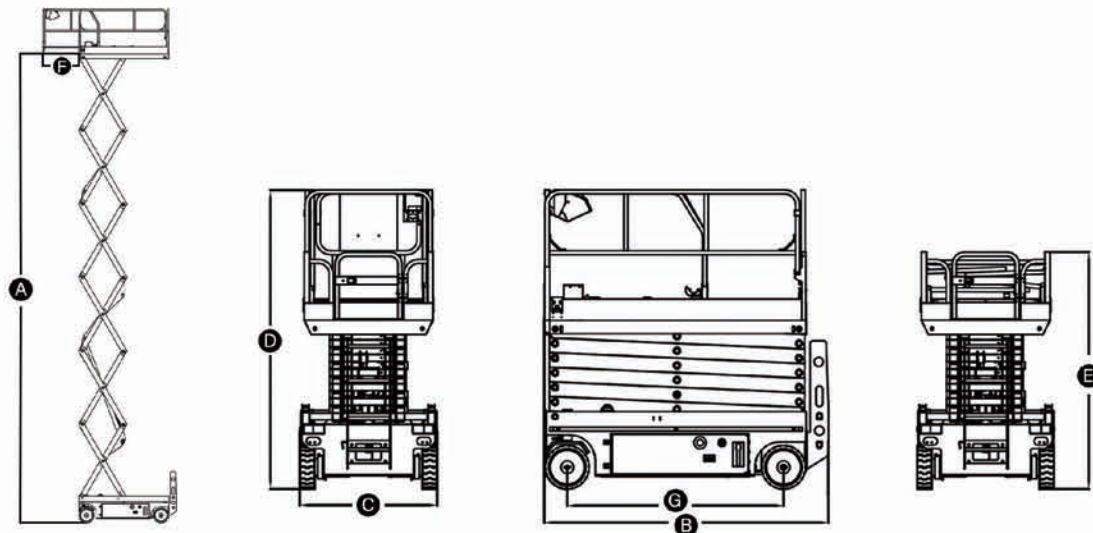

Model	Z10W	Z12W	Z14W
Specification			
Max. Working Height	11.8m	13.8m	15.8m
A Max. Platform Height	9.8m	11.8m	13.8m
Platform Length	2.3m	2.3m	2.7m
Platform Width	1.15m	1.15m	1.15m
B Overall Length	2.45m	2.45m	2.85m
C Overall Width	1.18m	1.18m	1.36m
D Overall Height-Guardrails Up	2.48m	2.6m	2.87m
E Overall Height-Guardrails Down	1.88m	2.0m	2.3m
F Extension Deck	0.9m	0.9m	0.9m
G Wheelbase	1.92m	1.92m	2.26m
Ground Clearance (Stowed/Raised)	0.1m/0.02m	0.1m/0.02m	0.1m/0.02m
Productivity			
Max. Platform Occupants	2	2	2
Platform Capacity	320kg	320kg	230kg
Platform Capacity-Extension Deck	113kg	113kg	113kg
Drive Height	Full Height	Full Height	Full Height
Gradeability-Stowed	25%	25%	25%
Turning Radius-Inside/Outside	0/2.8m	0/2.8m	0/3.3m
Raise/Lower Speed	3-5m/min	3-5m/min	3-5m/min
Drive Mode	2×2	2×2	2×2
Tire Type	Solid non-marking tire	Solid non-marking tire	Solid non-marking tire
Tire Size	φ380×127mm	φ380×127mm	φ381×127mm
Power			
Battery	4*6V/200Ah	4*6V/200Ah	4*12V/280Ah
Charger	24V/30A	24V/30A	24V/36A
Hydraulic System			
Hydraulic Oil Capacity	20L	20L	25L
Weight			
Machine Weight	2800kg	2900kg	3900kg

Tracked Scissor Lift

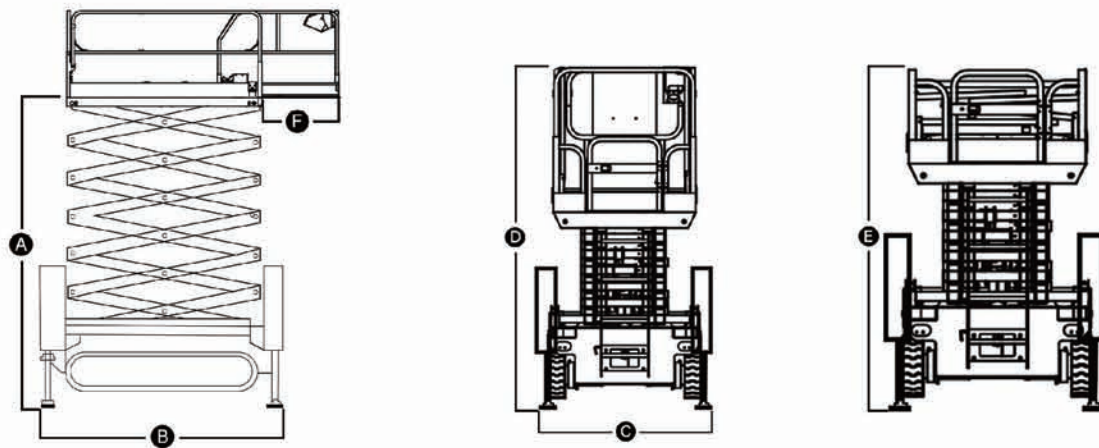

Model	Z08T	Z10T	Z12T
Specification			
Max. Working Height	9.8m	11.8m	13.8m
A Max. Platform Height	7.8m	9.8m	11.8m
Platform Dimensions (L*W*H)	2.3×1.15×1.1m	2.3×1.15×1.1m	2.3×1.15×1.1m
B Overall Length	2.77m	2.77m	2.77m
C Overall Width	1.55m	1.55m	1.55m
D Overall Height-Guardrails Up	2.47m	2.59m	2.71m
E Overall Height-Guardrails Down	1.86m	1.98m	2.1m
F Extension Deck	0.9m	0.9m	0.9m
Wheelbase	1.8m	1.8m	1.8m
Machine Weight	3450kg	3550kg	3650kg
Productivity			
Platform Capacity	320kg	320kg	320kg
Platform Capacity-Extension Deck	113kg	113kg	113kg
Max. Platform Occupants	2	2	2
High Driving Speed	3.5km/h	3.5km/h	3.5km/h
Low Driving Speed	0.8km/h	0.8km/h	0.8km/h
Gradeability-Stowed	30%	30%	30%
Lifting Speed-Raise	6-8m/min	6-8m/min	6-8m/min
Lifting Speed-Lower	10-12m/min	10-12m/min	10-12m/min
Longitudinal Leveling Front	8.5°	8.5°	8.5°
Longitudinal Leveling Rear	8.5°	8.5°	8.5°
Lateral Leveling	13°	13°	13°
Hydraulic System			
Hydraulic Oil Capacity	30L	30L	30L
Power			
Battery	8×6V/200Ah	8×6V/200Ah	8×6V/240Ah
Charger	48V/30A	48V/30A	48V/30A

Bi-Leveling Tracked Scissor Lift

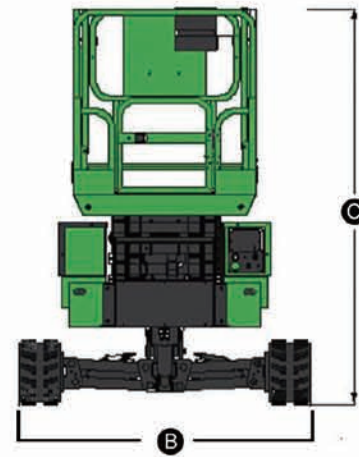
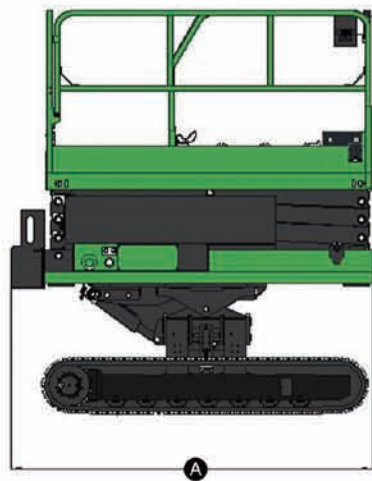

Model	Z06TSL	Z08TSL	Z10TSL	Z12TSL
Specification				
Max. Working Height	7.9m	10.3m	12m	14m
Max. Platform Height	5.9m	8.3m	10m	12m
Platform Dimensions	1.63×0.74m	2.28×1.136×1.26m	2.28×1.136×1.26m	2.28×1.136×1.26m
A Overall Length	2.02m	2.53m	2.53m	2.53m
B Overall Width	1.47m/1.3m	1.37m	1.37m	1.37m
C Overall Height-Guardrails Up	2.39m	2.835m	2.965m	3.095m
Overall Height-Guardrails Down	2m	2.327m	2.457m	2.587m
Extension Deck	0.9m	0.9m	0.9m	0.9m
Wheelbase	1.8m	1.8m	1.8m	1.8m
Machine Weight	1890kg	3398kg	3698kg	3998kg
Productivity				
Platform Capacity	250kg	250kg	250kg	250kg
Platform Capacity-Extension Deck	113kg	113.3kg	113.3kg	113.3kg
Max.Platform Occupants	2	2	2	2
High Driving Speed	2-3km/h	2-3km/h	2-3km/h	2-3km/h
Low Driving Speed	0.8-12km/h	0.8-12km/h	0.8-12km/h	0.8-12km/h
Gradeability-Stowed	40%	36%	36%	36%
Lifting Speed-Raise	6-8m/min	6-8m/min	6-8m/min	6-8m/min
Lifting Speed-Lower	10-12m/min	10-12m/min	10-12m/min	10-12m/min
Longitudinal Leveling Front	±15°	±15°	±15°	±15°
Longitudinal Leveling Rear	±20°	±20°	±20°	±20°
Lateral Leveling	±14°	±17°	±17°	±17°
Hydraulic System				
Hydraulic Oil Capacity	32L	32L	32L	32L
Power				
Battery	8X12V/160Ah	8×6V/200Ah	8×6V/200Ah	8×6V/200Ah
Charger	100-240VAC/35A	30A	30A	30A